

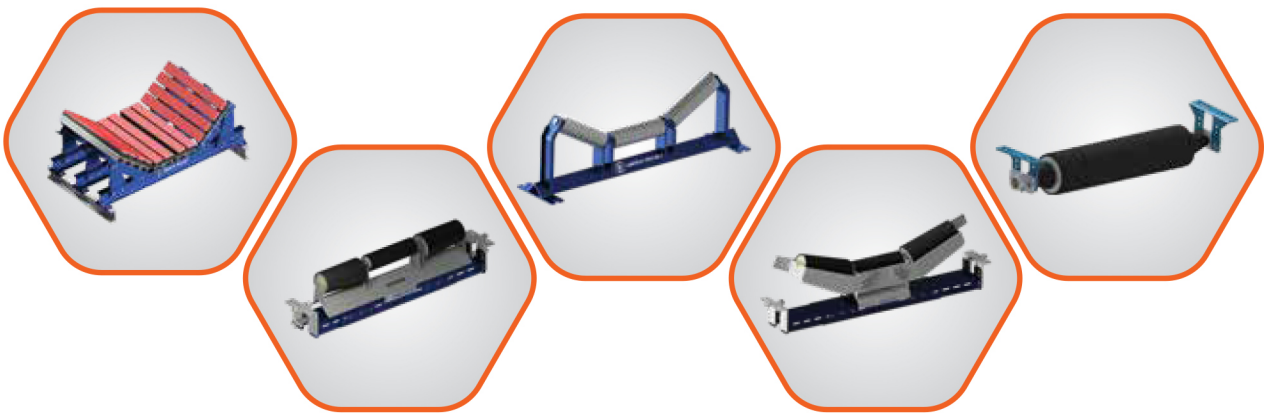

UNITECH PROJECT

INTELLIGENT CONVEYOR SYSTEM SOLUTIONS



*More Efficient, More Economic,
More Flexible, More Stronger.*



ABOUT US:

Unitech Project is an ISO 9001:2015 certified company where we constantly strive for quality at an economical price for all of our products. We have an exciting array of products which are deemed for customer satisfaction. We operate from our state-of - art factory in India where all our products are manufactured with utmost care.

COMPANY PROFILE:

We are manufacturer & exporter of all types of belt conveyor products and mining equipments which are used in the conveyor systems in Thermal Power Plants, Cement Plants, Mining Industries etc.

PRODUCTS:

1. Self Aligning Conveyor Idler
2. Self Aligning Return Idler
3. Return Tracker
4. Trough Tracker
5. Trough Conveyor idler
6. Flat Conveyor Idler
7. Heavy Duty Return Trackers
8. Impact Bed



1. SELF ALIGNING CONVEYOR IDLERS:

Self Aligning Conveyor Idlers are specially designed with exciting features, consisting of two conical idlers, one straight idler, two heavy load carrying interlocking arm and double bearing swiveling mechanism. This system helps to auto control the belt sway, prevent belt damage and material spillage.

FEATURES

- ✓ **Exceptional Performance:** Two conical rollers and double bearing swiveling mechanism offers fast and reactive tracking to even the slightest belt sway.
- ✓ **Lagging:** High quality wear resistant rubber lagging and diamond cut groove provides perfect grip with the belt which helps to track the belt easily.
- ✓ **Double Bearings:** Self-lubricated deep groove ball bearing and angular contact bearing pivot system is designed to be used in heavy-duty conditions.
- ✓ **Corrosion Resistance Body:** The structure is made with high strength mild steel and painted with powder coated paint to make it corrosion free.
- ✓ **Individual Roller Replacement:** Rollers can be replaced individually.
- ✓ **Maintenance Free:** Oil bath lubricated bearing does not require any greasing.
- ✓ **Easy to Install:** Width, height and trough angle can be adjusted flexibly according to the fixing and operational requirement.

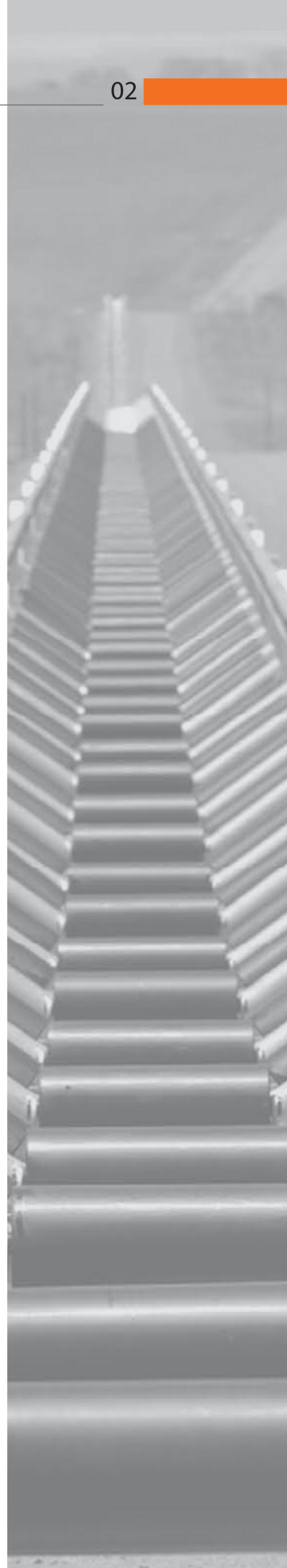

DESIGN ADVANTAGES:

SENSITIVE CONICAL ROLLER:

- ✔ Sensitive track the belt even during the slightest belt sway.
- ✔ Vibration free rolling action at running condition.
- ✔ Wear resistance rubber provides maintenance free long life of belt and idler.
- ✔ Diamond cut groove provides proper gripping and helps to track the belt continuously.



BOTH SIDE FLEXIBLE INTERLOCKING ARM:

- ✔ Trough angle can be adjusted variably from 5°-45°.



MAINTENANCE FREE DUST RESISTANCE BEARING ASSEMBLY:

- ✔ Closed bearing housing does not allow any dust, moisture and contaminated particles to enter inside thus preventing jamming.
- ✔ Double bearings are used for carrying heavy load.
- ✔ Self-lubricated bearings are used, thus do not require any greasing from outside.



AUTO DUST REMOVING SWAY GUARD PLATE:

- ✔ A taper sway guard plate controls the swiveling system during belt sway.
- ✔ No dust particles can settle on this taper surface.



ADJUSTABLE FRAME:

- ✔ The system has the ability to adjust the base frames width & height as per the requirement and can be installed easily to the main line.

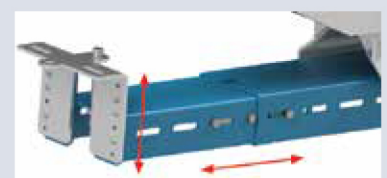

TECHNICAL DATA OF SELF ALIGNING CONVEYOR IDLERS:

MODEL NO	BELT WIDTH [MM]	X (MIN-MAX) [MM]	H (MIN-MAX) [MM]	Y [MM]	TROUGHING ANGLE D (MIN-MAX)	WEIGHT (Kg)
SCI 600	600	835 - 1036	16 - 169	150	15°- 45°	80
SCI 650	650	960 - 1160	96 - 226	150	15°- 45°	85
SCI 800	800	1104 - 1216	72 - 169	150	15°- 45°	98
SCI 1000	1000	1254 - 1556	71 - 169	150	15°- 45°	112
SCI 1100	1100	1220 - 1356	71 - 170	150	15°- 45°	112
SCI 1200	1200	1430 - 1928	196 - 286	180	15°- 45°	180
SCI 1400	1400	1730 - 2032	142 - 277	180	15°- 45°	208
SCI 1600	1600	1874 - 2180	196 - 286	180	15°- 45°	217
SCI 1800	1800	2090 - 2390	201 - 286	180	15°- 45°	234
SCI 2000	2000	2530 - 2832	142 - 287	180	15°- 45°	348

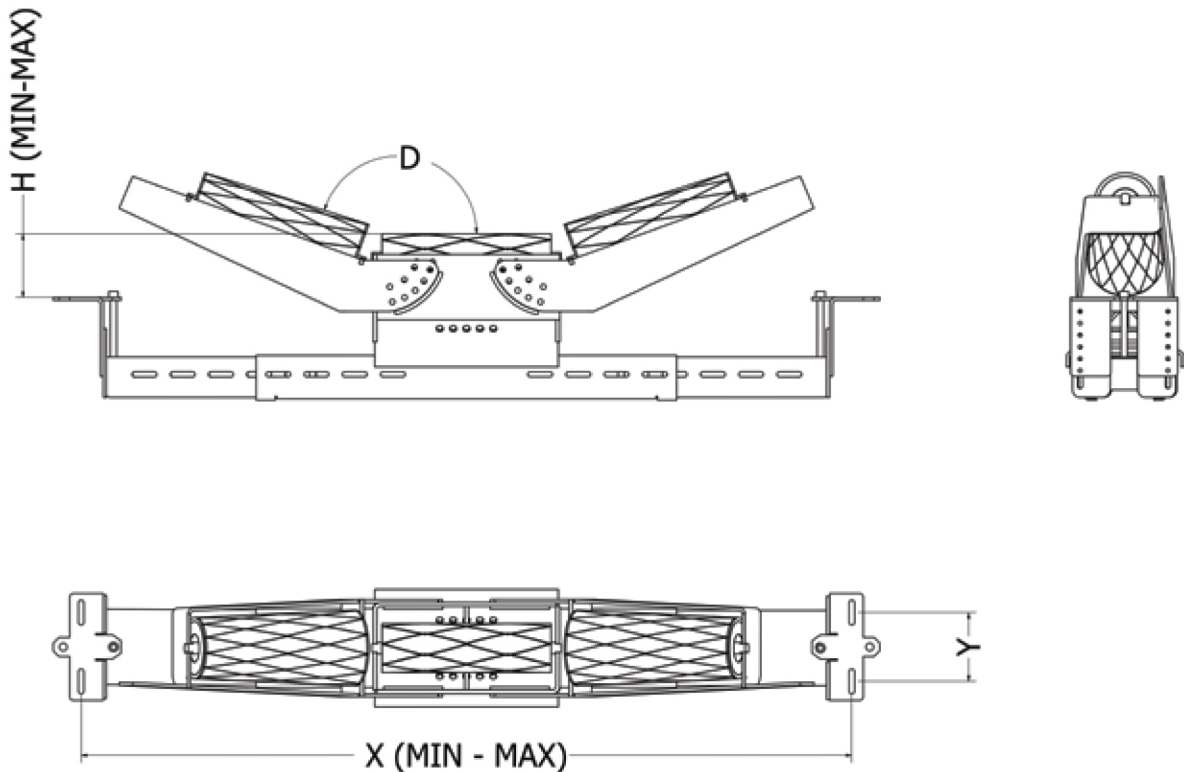

2. SELF ALIGNING RETURN IDLERS:

Self Aligning Return Idlers are used to correct the misalignment of the belt on the return side. Normal spacing between two self-aligning return idler is 100 to 150 feet. Available in (600 - 2000mm) belt width.

FEATURES

- ✓ **Exceptional Performance:** Two conical rollers and double bearing swiveling mechanism offers fast and reactive tracking to even the slightest belt sway.
- ✓ **Lagging:** High quality wear resistant rubber lagging and diamond cut groove provides perfect grip with the belt which helps to track the belt easily.
- ✓ **Double Bearings:** Self-lubricated deep groove ball bearing and angular contact bearing pivot system is designed for its use in heavy-duty conditions.
- ✓ **Individual Roller Replacement:** Rollers can be replaced individually.
- ✓ **Maintenance Free:** Oil bath lubricated bearing does not require any greasing.
- ✓ **Easy to Install:** Width and height can be adjusted flexibly according to the fixing and operational requirement.

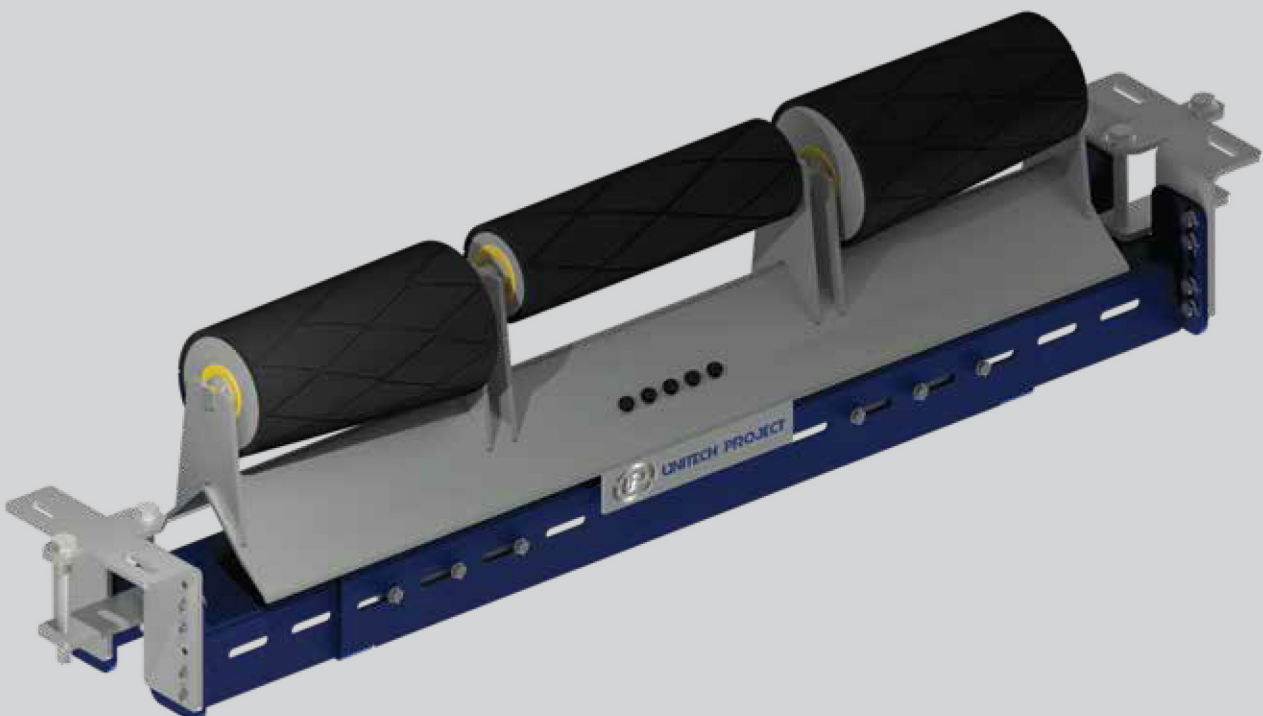

TECHNICAL DATA OF SELF ALIGNING RETURN IDLERS:

MODEL NO	BELT WIDTH [MM]	X (MIN-MAX) [MM]	H (MIN -MAX) [MM]	Y [MM]	WEIGHT (kg)
SRI 600	600	846 - 1026	36 - 170	150	55
SRI 650	650	960 - 1160	98 - 186	150	60
SRI 800	800	1208 - 1408	98 - 186	150	67
SRI 1000	1000	1358 - 1558	98 - 186	150	72
SRI 1100	1100	1452 - 1570	98 - 186	150	74
SRI 1200	1200	1632 - 1832	176 - 307	180	139
SRI 1400	1400	1758 - 2032	173 - 308	180	150
SRI 1600	1600	1980 - 2182	177 - 308	180	160
SRI 1800	1800	2180 - 2380	177 - 308	180	182
SRI 2000	2000	2530 - 2832	182 - 316	180	256

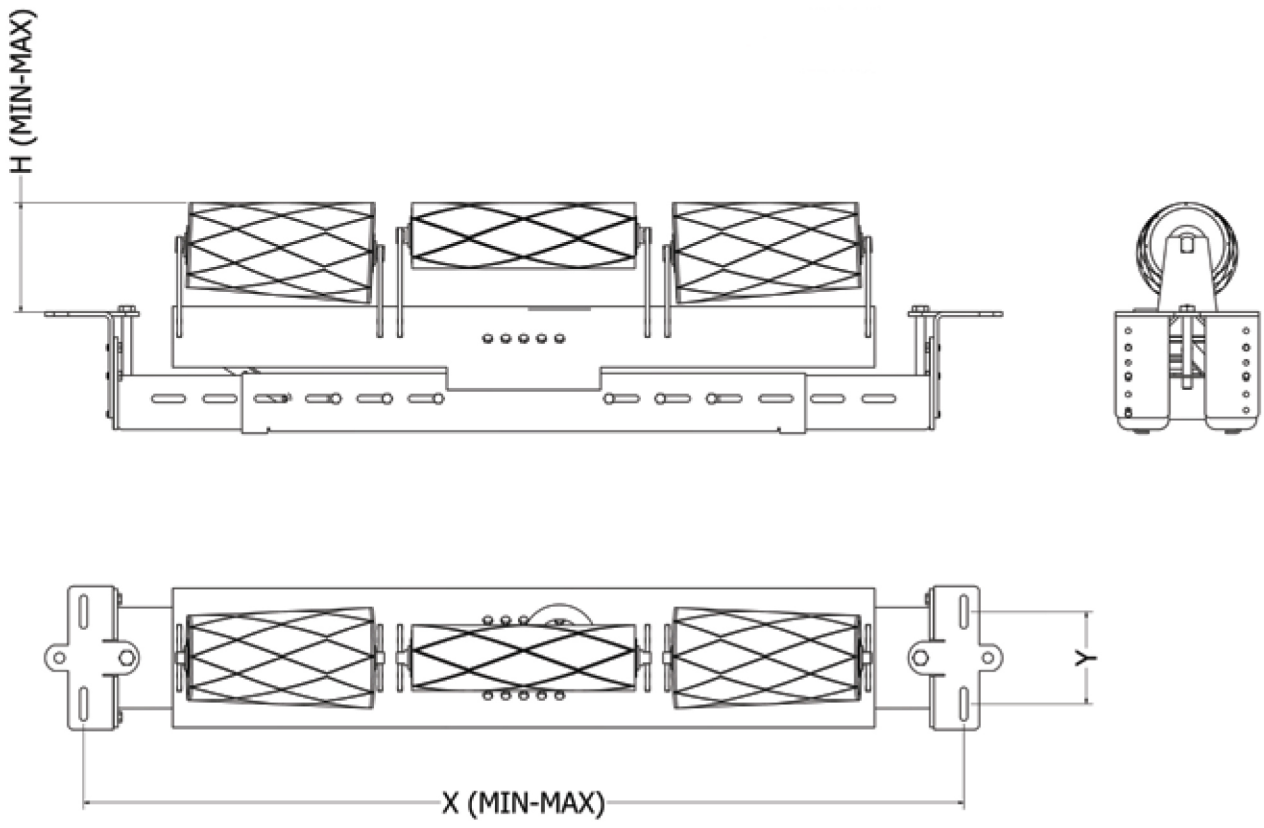

3. TROUGH TRACKERS:

Trough Trackers helps to auto align the misaligned belt and take heavy load on the carrying side of the conveyor system. This central pivoting system along with the two wing rollers helps to track the belt effectively.

FEATURES

- ✔ **Exceptional Performance:** Trough Trackers are designed with a high strength shaft and double pipe base which helps to preventing the shaft from bending. Steel bearing housings are welded into the barrel.
- ✔ **Rugged Sealing System:** Steel end caps are pressed into the bearing housing.
- ✔ **Lagging:** Available in high abrasive rubber lagging.
- ✔ **Double Bearings:** Deep groove ball bearing & thrust bearings have been used for heavy-duty and high-speed applications.
- ✔ **Easy to Install:** Width and height can be adjusted flexibly according to the fixing and operational requirements.



TECHNICAL DATA OF TROUGH TRACKERS:

MODEL NO	BELT WIDTH [MM]	A [MM]	B (MIN-MAX) [MM]	Y [MM]	WEIGHT (Kg)
TT 600	600	838	200-300	120	45
TT 650	650	890	200-300	120	45
TT750	750	990	200-300	120	48
TT800	800	1040	200-300	120	48
TT900	900	1144	210-330	225	57
TT1000	1000	1240	210-330	225	57
TT1050	1050	1296	210-330	225	59
TT1200	1200	1448	210-330	225	61
TT1350	1350	1600	210-330	225	78
TT1400	1400	1700	210-330	225	81
TT 1500	1500	1752	210-330	225	83
TT 1600	1600	1900	210-330	225	118
TT1650	1650	1904	210-330	225	124
TT 1800	1800	2058	210-330	225	133

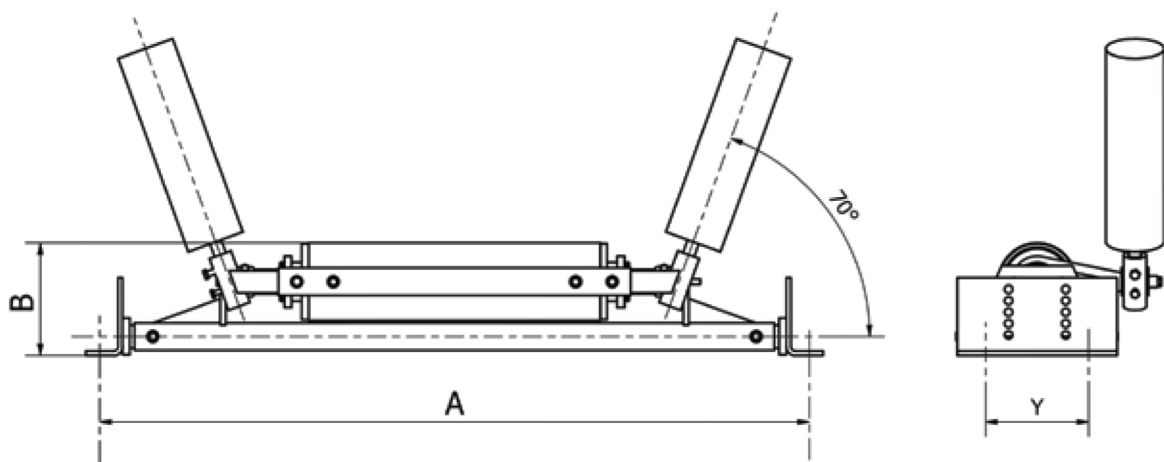

4. RETURN TRACKERS:

Return Trackers are used to auto align the misaligned belt more effectively on the return side of the conveyor system. This central pivoting system and taper edge, works as a steering mechanism which helps to track the belt and keep it running true constantly.

FEATURES

- ✔ **Bearings:** Deep groove ball bearings are used here with covered bearing housing and plastic end caps for better performance.
- ✔ **Lagging:** Covered with high abrasive natural rubber. Also available in polyurethane lagging.
- ✔ **Performance:** Excellent and reliable performance in high speed conveyor.
- ✔ **Maintenance Free:** Sealed bearing does not require any greasing.
- ✔ **Easy to Install:** Can be installed easily with the mounting brackets

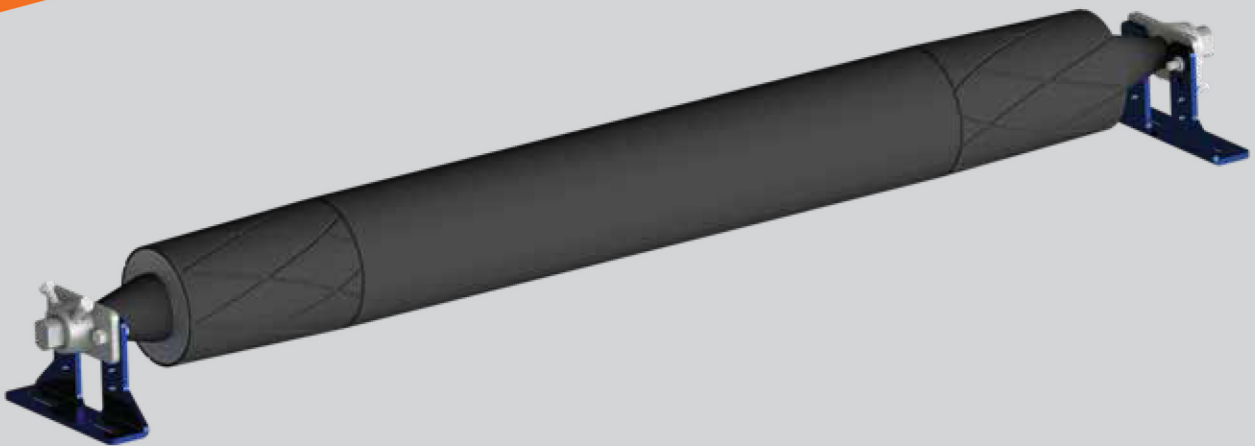

TECHNICAL DATA OF RETURN TRACKERS:

MODEL NO	BELT WIDTH [MM]	A [MM]	B [MM]	Y [MM]	WEIGHT (Kg)
RT 600	600	838	1000	140	37
RT 650	650	890	1050	140	39
RT750	750	990	1150	140	42
RT800	800	1040	1200	140	45
RT900	900	1144	1300	140	49
RT1000	1000	1240	1400	140	52
RT1050	1050	1296	1450	140	53
RT1200	1200	1448	1600	140	59
RT1350	1350	1600	1780	140	71
RT1400	1400	1700	1830	140	74
RT 1500	1500	1752	1930	140	78
RT 1600	1600	1895	2320	140	85

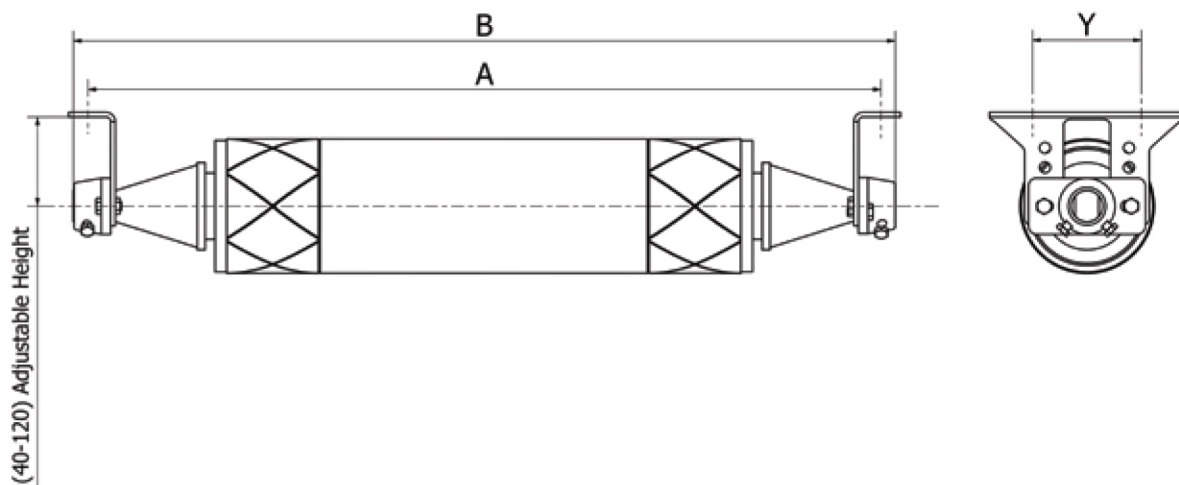

5. TROUGH CONVEYOR IDLERS:

Trough Conveyor Idlers helps to ensure the load carrying capacity of the conveyor belt along the entire length of the belt. Trough Conveyor Idlers are available in 20°, 30°, 35° and 45° trough angle.

FEATURES

- ✓ **Bearings:** Self-lubricated deep groove ball bearings are used, thus do not require any greasing from outside.
- ✓ **Individual Roller Replacement:** Rollers can be replaced individually.
- ✓ **Performance:** Excellent and reliable performance in high speed conveyor.
- ✓ **Maintenance Free:** Closed bearing housing does not allow any dust, moisture and contaminated particle to enter inside thus preventing jamming.
- ✓ **Corrosion Resistance Body:** Idler frame is manufactured with high strength mild steel and painted with powder coated paint to make it corrosion free.



TECHNICAL DATA OF TROUGHED CONVEYOR IDLERS:

MODEL NO	BELT WIDTH [MM]	A [MM]	B [MM]	Y [MM]	WEIGHT (Kg)
TI600	600	840	245	165	32
TI 650	650	890	245	200	35
TI750	750	990	245	200	37
TI800	800	1040	245	200	40
TI900	900	1140	245	200	42
TI1000	1000	1240	245	200	47
TI1050	1050	1295	245	200	49
TI1200	1200	1450	245	200	53
TI1350	1350	1600	245	200	56
TI1400	1400	1650	245	200	59
TI 1500	1500	1775	245	200	63
TI 1600	1600	1900	245	200	68
TI 1800	1800	2100	245	200	87
TI 2000	2000	2300	245	200	94

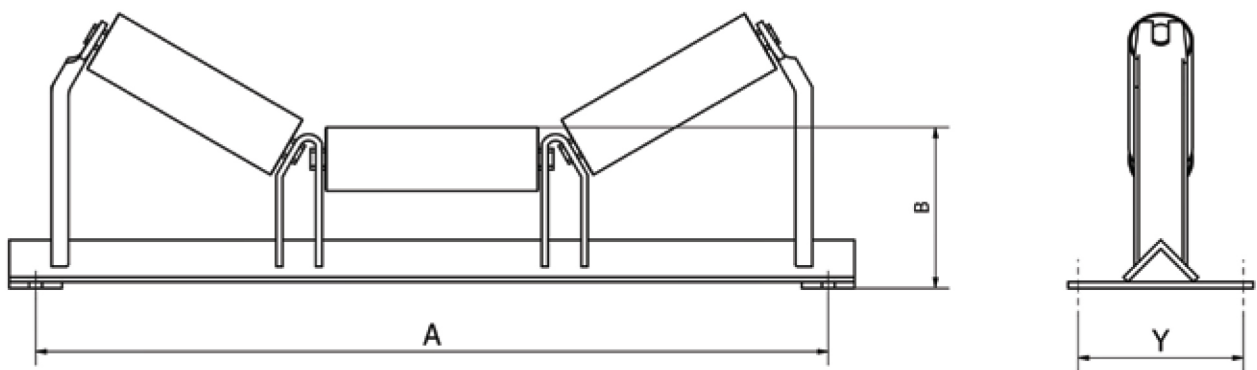

6. FLAT CONVEYOR IDLERS:

The purpose of using a Flat Conveyor Idler is to support the belt on the carrying side of flat belt conveyor system. These idlers consist of a single steel roller mounted on two drop brackets.

FEATURES

- ✓ **Bearings:** Self-lubricated deep groove ball bearings are used thus do not required any greasing from outside.
- ✓ **Performance:** Excellent and reliable performance in high speed conveyor.
- ✓ **Maintenance Free:** Closed bearing housing does not allow any dust, moisture and contaminated particles to enter inside thus preventing jamming.
- ✓ **Corrosion Protection:** The entire body is powder-coated to protect it from corrosion.

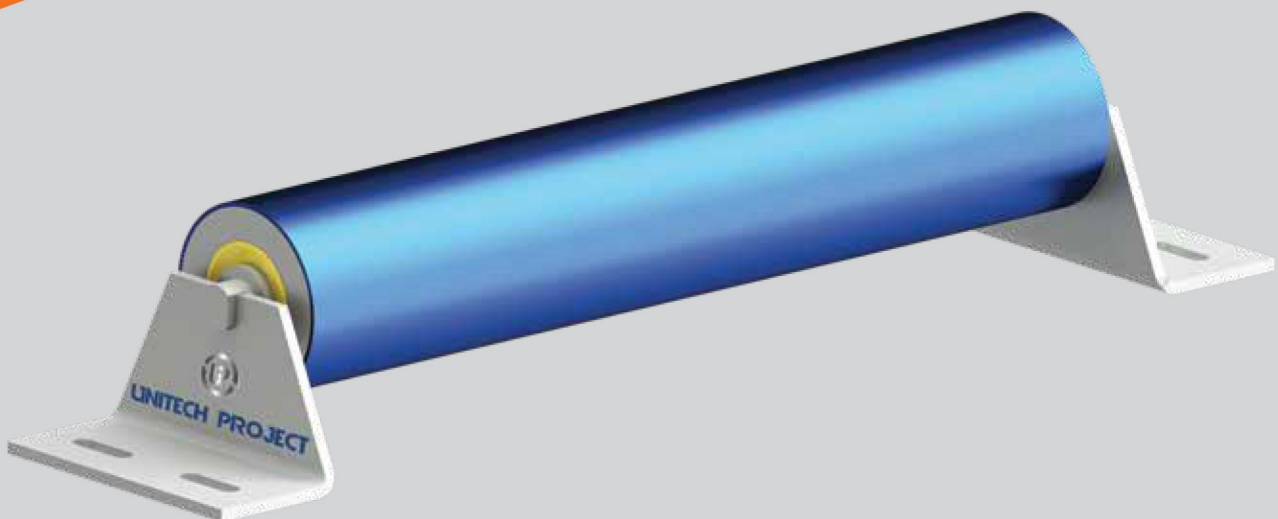

TECHNICAL DATA OF FLAT CONVEYOR IDLERS:

MODEL NO	BELT WIDTH [MM]	A [MM]	B [MM]	Y [MM]	WEIGHT (Kg)
FI 600	600	840	160	100	15
FI 650	650	890	160	100	17
FI750	750	990	160	100	18
FI800	800	1040	160	100	20
FI900	900	1140	160	100	22
FI1000	1000	1240	160	100	33
FI1050	1050	1295	160	100	35
FI1200	1200	1450	160	100	39
FI1350	1350	1600	160	100	43
FI1400	1400	1650	160	100	48
FI 1500	1500	1775	160	100	52
FI 1600	1600	1900	160	100	55
FI 1800	1800	2100	160	100	59
FI 2000	2000	2300	160	100	65

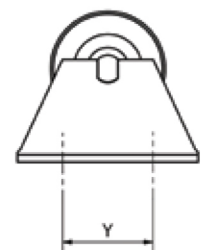
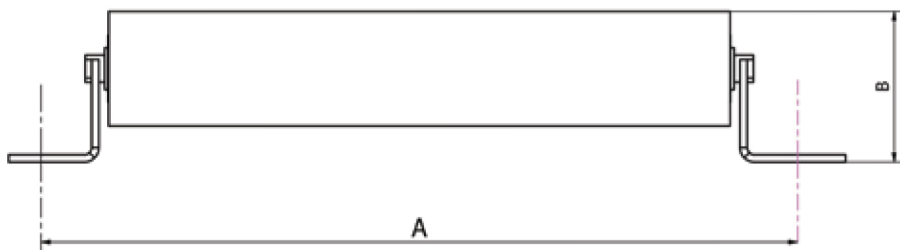

7. HEAVY DUTY RETURN TRACKERS:

Heavy Duty Return Trackers are used to auto align the misaligned belt on the return side of the conveyor system. This central pivoting system and dual taper edge rollers, works as a steering mechanism similar to return trackers. These trackers are suitable for large belt width conveyor systems.

FEATURES

- ✓ **Exceptional Performance:** Dual taper edge rollers and centre pivoted swiveling mechanism offers fast and reactive tracking to even the slightest belt sway.
- ✓ **Lagging:** High quality wear resistant rubber lagging and diamond cut groove provides perfect grip with the belt which helps to track the belt easily.
- ✓ **Bearings:** Here we have used self-lubricated deep groove ball bearings therefore additional greasing from outside is not required.
- ✓ **Maintenance Free:** Closed bearing housing does not allow any dust, moisture and contaminated particles to enter inside thus preventing jamming.
- ✓ **Corrosion Protection:** The entire body is powder-coated to protect it from corrosion.



TECHNICAL DATA OF FLAT RETURN CONVEYOR IDLERS:

MODEL NO	BELT WIDTH [MM]	A [MM]	B [MM]	C [MM]	WEIGHT (Kg)
HDRT 1200	1200	1448	1326	150	121
HDRT 1350	1350	1600	1476	150	125
HDRT 1400	1400	1700	1526	150	128
HDRT 1500	1500	1752	1626	150	128
HDRT 1600	1600	1900	1776	150	135
HDRT 1650	1650	1905	1776	150	135
HDRT 1800	1800	2058	1926	150	137
HDRT 2000	2000	2260	2146	150	137
HDRT 2100	2100	2362	2246	150	140
HDRT 2200	2200	2464	2346	150	142
HDRT 2300	2300	2515	2446	150	149
HDRT 2400	2400	2668	2546	150	152
HDRT 2500	2500	2770	2646	150	153
HDRT 2600	2600	2820	2746	150	156

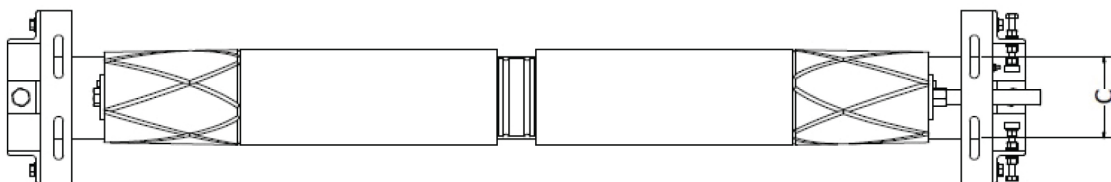
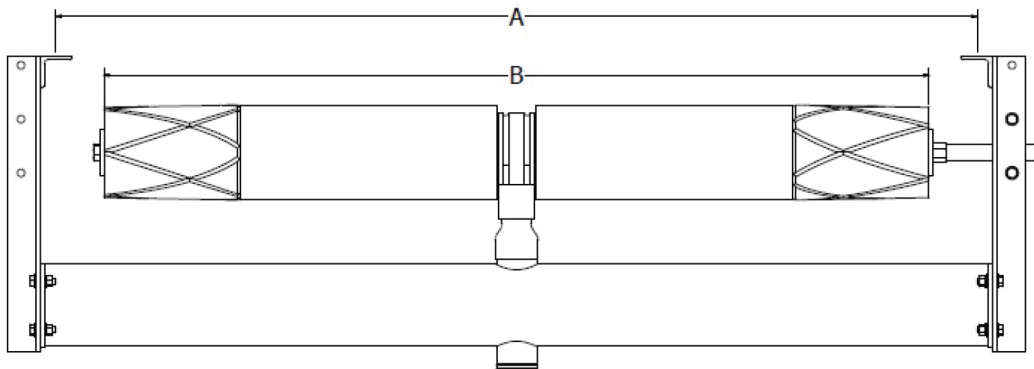

8. IMPACT BEDS:

Impact Bed structures as well as the high quality rubber impact pads are designed & manufactured in such a way so that it can withstand huge impact load falling on it. Impact pads are made after bonding UHMWPE & rubber which helps in taking extra load. The impact beds are customisable and thus can be manufactured both according to our own standard or as per customer drawing.

FEATURES

- ✓ **Absorb Heavy Impact Load:** High quality rubber pads absorb heavy impact load.
- ✓ **Long Lasting:** Heavy duty steel frame and wear resistance UHMWPE layer on the rubber pad provides long life to the conveyor system.
- ✓ **Reduce Spillage:** Continuous support along the loading station reduces material spillage.
- ✓ **Lower Maintenance Cost:** Impact bar can be replaced individually.
- ✓ **Corrosion Protection:** The entire frame is powder-coated to provide corrosion free protection throughout the lifespan of the Impact bed structure.

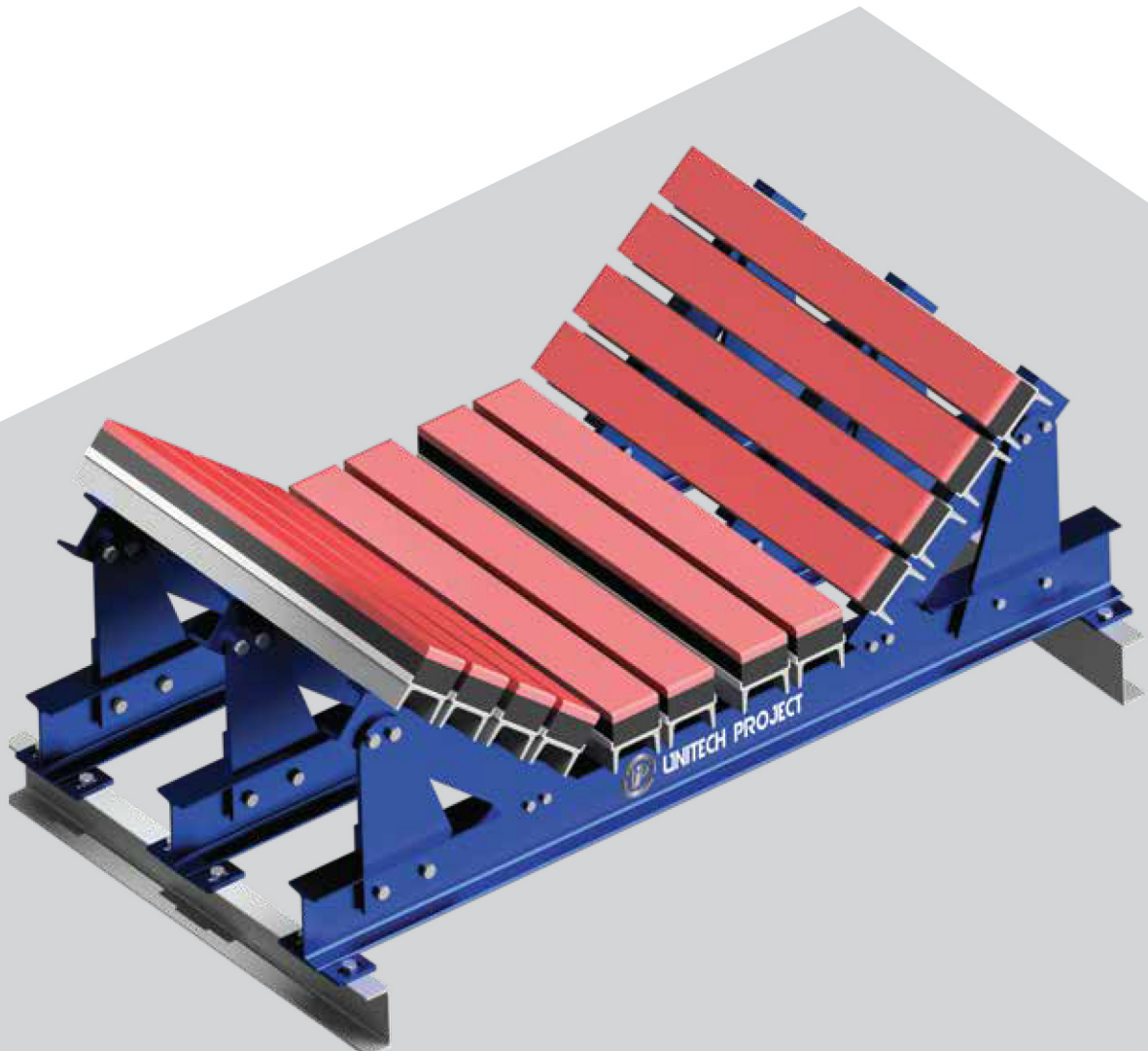

OUR CERTIFICATION:



Certificate of Registration

This certificate has been awarded to

Unitech Project

Office- 4/22, G.T. Road (S), Howrah, West Bengal, 711101, India, Unit-I- 20/2, Sarat Dutta Lane, Howrah, West Bengal, 711101, India, Unit-II- Lakshmanpur Industrial Estate, Tentulkuly, Domjur, Howrah, West Bengal, 711409, India

In recognition of the organization's Quality Management System which complies with

ISO 9001:2015

The scope of activities covered by this certificate is defined below

Design, Manufacture and Supply of Fabricated and Machined Items, Industrial Valves, Testing Equipment, Conveyor for Steel Plant, Power Plant, Railways and General Engineering Sectors

Certificate Number 69931/B/0001/UK/En			
Date of Issue of Certification Cycle	Issue Number	Certificate Expiry Date	Certification Cycle
01 June 2021	3	31 May 2024	3
Revision Date	Revision Number	Original Certificate Issue Date	Scheme Number
27 May 2021	0	01 June 2015	n/a

For detailed explanation for the data fields above, refer to <http://www.urs-holdings.com/logos-and-regulations>

Issued by

On behalf of the Schemes Manager



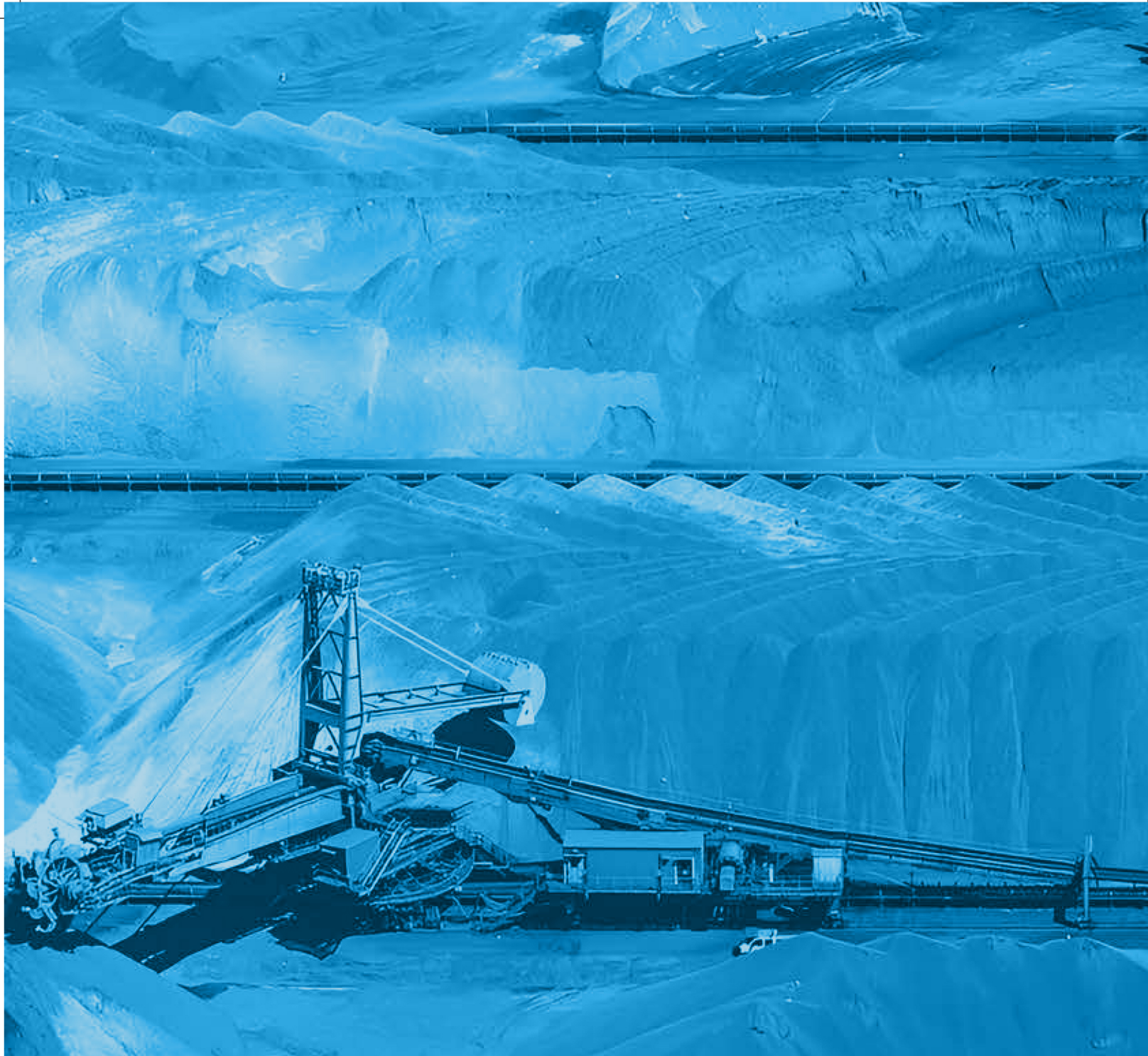

UNITECH PROJECT

📍 20/2 Sarat Dutta Lane, Howrah - 711101,
West Bengal, India

☎ 033 26430009

☎ +91 7603023592

✉ info@unitechproject.com

🌐 www.unitechproject.com